

**“Modelling and control using
ENERGETIC MACROSCOPIC REPRESENTATION”**
Application to hybrid electric vehicles and others

26-30 March 2024

Noida, India

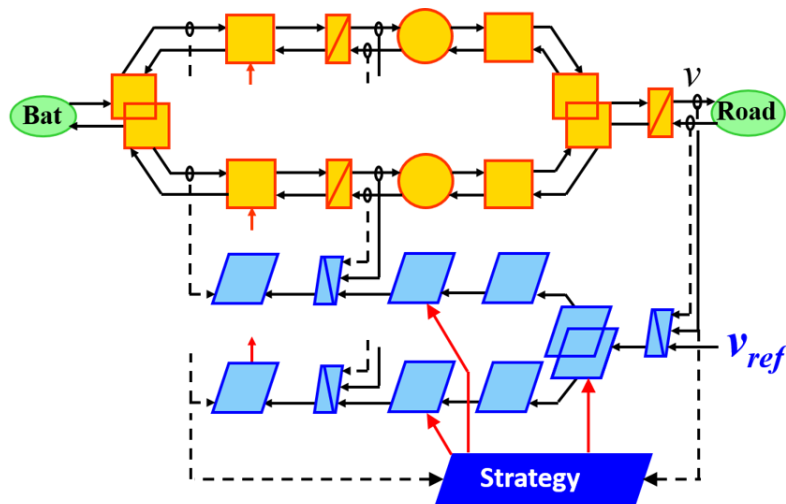

EMR of an Electric Vehicle



EMR in-presence attendees



EMR speakers



EMR on-line attendees

SUPPORTS

OBJECTIVE

This workshop is focused on the **Energetic Macroscopic Representation (EMR)** methodology for modelling and control of complex electromechanical systems.

This Summer School is aimed at Master and PhD students, Engineers and scientists, from both academia and industry, who must **model and control new multi-physical systems** such as industrial multi-drive systems, traction and propulsion systems, hybrid electric vehicles, or renewable energy generation systems.

EMR is a graphical formalism that was introduced in 2000 to describe complex electromechanical systems. EMR has since been extended to complex multi-physical systems (thermal science, electrochemistry, fluid mechanics ...). EMR is based on the action-reaction principle to organize the interconnection of models of sub-systems according to the physical causality (i.e integral causality). This description highlights energetic properties of the system (energy accumulation, conversion and distribution). Moreover, an **inversion-based control** can be systematically deduced from EMR using specific inversion rules.

Compared with other graphical description, such as Bond Graphs or Causal Ordering Graphs (COG), EMR has a more global energetic view and contributes to system's control design. It differs from structural description tools such as Physic Modelling Language (PML) using Object-Oriented Modelling Language, which makes its libraries to be coupled in the same way as physical units. EMR is focused on the system function and not only on the system structure. EMR gives insights into the real energy operation of systems and allows a deep understanding of its potentialities from a dynamic point of view.

In short, the distinct features of EMR lie in its clarity of physical concepts, as well as their physical causality, and its functional description rather than a structural description. It hence contributes significantly to the design of control and energy management of systems.

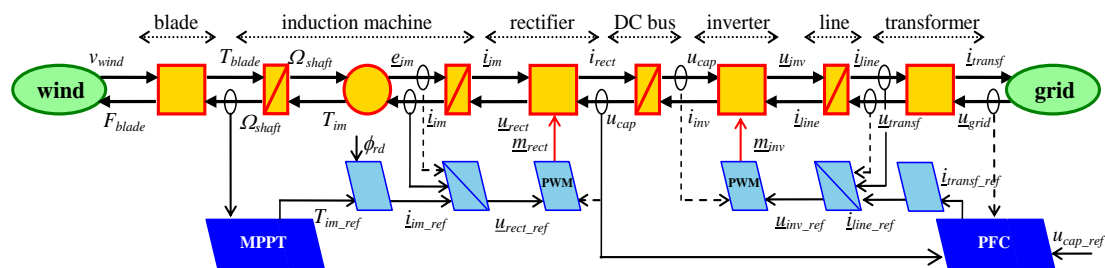

Energetic Macroscopic Representation of a Wind Energy Conversion System

PREVIOUS EMR SUMMER SCHOOLS

Photos of EMR'23, Lille, France



EMR'06 - Lille (France) / EMR'08 - Harbin (China), EMR'09 - Trois-Rivières (Canada) / EMR'11 - Lausanne (Switzerland), EMR'12 - Madrid (Spain) / EMR'13 - Lille (France), EMR'14 - Coimbra (Portugal) / EMR'15 - Lille (France), EMR'16 - Montreal (Canada) / EMR'17 - Lille (France), EMR'18 - Hanoi (Vietnam) / EMR'19 - Lille (France) EMR'20 (Ovideo, Spain) has been cancelled due to COVID-19 crisis, EMR'21 - Lille (France), EMR'22 - Sion (Switzerland), EMR'23 - Lille (France)

SIMULATION TRAINING SESSION

The aim of this Summer School is to **give a first-hand experience in practice of using EMR and inversion-based control**. Three simulation training sessions will use MATLAB®-Simulink®. Attendees will simulate a complete system and its control using EMR methodology. They will choose to study an electric vehicle, a photovoltaic system or a wind energy conversion system. An EMR library will be provided to all attendees.

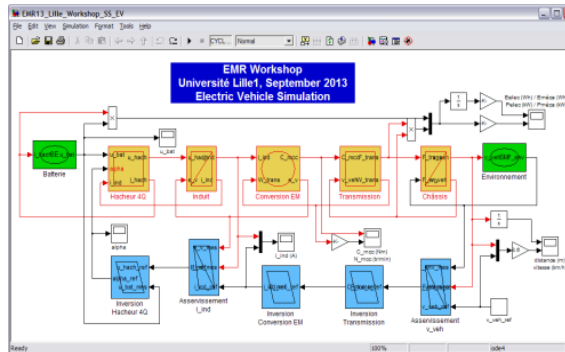

MATLAB®-Simulink® model of an Electric Vehicle (orange) and its control (blue) derived from EMR

PRELIMINARY PROGRAM

EM24 at a Glance

| | | | | Local | | | | | | | | |
|----------|-------|---------|---------|-------------------|-------------------|-------------------|--|------------|-------------------|-------------------|-----------------------------------|--------------------------------|
| Montreal | Paris | Delhi | Beijing | | | | | Tuesday 26 | Wednesday 27 | Thursday 28 | Saturday 30 | |
| UCT-4 | UTC+2 | UCT+5.5 | UTC+7 | | | | | | | | | |
| 11:30 | 5:30 | 9:00 | 10:30 | | | | | | Simulation part 1 | Simulation part 2 | Simulation part 3 | simulation connexion from Asia |
| 11:50 | 5:50 | 9:20 | 10:50 | | | | | | | | | In presence in India |
| 0:10 | 6:10 | 9:40 | 11:10 | | | | | | | | | |
| 0:30 | 6:30 | 10:00 | 11:30 | | | | | | | | | |
| 0:50 | 6:50 | 10:20 | 11:50 | | | | | | | | | |
| 1:10 | 7:10 | 10:40 | 12:10 | | | | | | | | | |
| 1:30 | 7:30 | 11:00 | 12:30 | | | | | | | | | |
| 1:50 | 7:50 | 11:20 | 12:50 | | | | | | | | | |
| 2:10 | 8:10 | 11:40 | 13:10 | | | | | | | | | |
| 2:30 | 8:30 | 12:00 | 13:30 | | | | | | | | | |
| 2:50 | 8:50 | 12:20 | 13:50 | | | | | | | | | |
| 3:10 | 9:10 | 12:40 | 14:10 | | | | | | | | | |
| 3:30 | 9:30 | 13:00 | 14:30 | Intro | Organization | Actuators | | | | | | |
| 3:50 | 9:50 | 13:20 | 14:50 | Organization | Industry-academ | Dual motors | | | | | | |
| 4:10 | 10:10 | 13:40 | 15:10 | Systemics | Smart materials | Education | | | | | | |
| 4:30 | 10:30 | 14:00 | 15:30 | Description | Battery HIL | EMS example | | | | | | |
| 4:50 | 10:50 | 14:20 | 15:50 | Break | Break | Break | | | | | lectures on | |
| 5:10 | 11:10 | 14:40 | 16:10 | Control | Application 1 | Application 5 | | | | | concepts | |
| 5:30 | 11:30 | 15:00 | 16:30 | RES example | Application 2 | Application 6 | | | | | application | |
| 5:50 | 11:50 | 15:20 | 16:50 | FCV example | Application 3 | Application 7 | | | | | for all | |
| 6:10 | 12:10 | 15:40 | 17:10 | Break | Break | Break | | | | | | |
| 6:30 | 12:30 | 16:00 | 17:30 | EV example | Application 4 | Application 8 | | | | | | |
| 6:50 | 12:50 | 16:20 | 17:50 | Summarization | Summarization | Summarization | | | | | | |
| 7:10 | 13:10 | 16:40 | 18:10 | | | | | | | | | |
| 7:30 | 13:30 | 17:00 | 18:30 | | | | | | | | | |
| 7:50 | 13:50 | 17:20 | 18:50 | | | | | | | | | |
| 8:10 | 14:10 | 17:40 | 19:10 | Simulation part 1 | Simulation part 2 | Simulation part 3 | | | | | | |
| 8:30 | 14:30 | 18:00 | 19:30 | | | | | | | | | |
| 8:50 | 14:50 | 18:20 | 19:50 | | | | | | | | simulation connexion from America | |
| 9:10 | 15:10 | 18:40 | 20:10 | | | | | | | | Europe | |
| 9:30 | 15:30 | 19:00 | 20:30 | | | | | | | | Africa | |
| 9:50 | 15:50 | 19:20 | 20:50 | | | | | | | | | |
| 10:10 | 16:10 | 19:40 | 21:10 | | | | | | | | | |
| 10:30 | 16:30 | 20:00 | 21:30 | | | | | | | | | |
| 10:50 | 16:50 | 20:20 | 21:50 | | | | | | | | | |
| 11:10 | 17:10 | 20:40 | 22:10 | end of Day | end of day | end of day | | | | | | |

**This workshop is co-organized by Amity University Uttar Pradesh
(Noida) & University of Lille (France).**

Chairperson

Prof.(Dr.) Balvinder Shukla, Vice Chancellor, AUUP, Noida

Co-chairs

Prof. Vivek KUMAR,
Professor and head, Amity Institute of Technology
AUUP Noida

Prof. Alain BOUSCAYROL
(University of Lille, L2EP, IEEE-VTS, MEGEVH,
France)

Program director

Dr. Bedatri MOULIK
Assistant Professor, Amity Institute of
Technology
AUUP Noida

Organization committee

Dr. Ayoub AROUA (University of Lille, L2EP, France)
Dr. Eswara K Mussada, Associate professor, Amity Institute of Technology, AUUP Noida
Dr. Puran Singh, Assistant professor, Amity Institute of Technology, AUUP Noida
Dr. Gaurav Ninawe, Assistant professor, Amity Institute of Technology, AUUP Noida
Dr. Gurpreet Singh Saini, Assistant professor, Amity Institute of Technology, AUUP Noida
Dr. Anil Kumar, Assistant professor, Amity Institute of Technology, AUUP Noida
Dr. Shailendra S. Chauhan, Assistant professor, Amity Institute of Technology, AUUP Noida

EMR International Scientific Committee

Chair: Prof. Alain BOUSCAYROL (University of Lille, L2EP, IEEE-VTS, MEGEVH, France)
Dr. Bedatri MOULIK (Amity University, IEEE-VTS India)
Dr. Philippe BARRADE (University of Applied Sciences of Sion, E-VTS Switzerland)
Prof. Loïc BOULON (Université du Québec à Trois-Rivières, IRH, IEEE-VTS, Canada)
Prof Lucia GAUCHIA, University of Carlos III Madrid (Spain)
Prof. Christophe GIRAUD-AUDINE (Arts et Métiers Institute of Technology, L2EP, France)
Prof. Daniel HISSEL (University of Franche Comté, FEMTO-ST, IEEE-VTS, MEGEVH, France)
Prof. Eric HITTINGER (Rochester Institute of Technology USA)
Prof. Betty LEMAIRE-SEMAIL (University of Lille, L2EP, France)
Dr. Clément MAYET (University of Lille, L2EP, IEEE-VTS, France)
Dr. Daniel MONTESINOS (Universitat Politècnica de Catalunya, Spain)
Prof. Paulo PEREIRINHA (Polytechnic Institute of Coimbra, INESC Coimbra, IEEE-VTS, Portugal)
Prof TA Cao Minh (Hanoi University of Sciences and Technology, IEEE-VTS, Vietnam)
Prof. João Pedro TROVÃO (Université de Sherbrooke, e-TESS Lab., IEEE-VTS, Canada)
Dr VO Duy Thanh (Hanoi University of Sciences and Technology, IEEE-VTS, Vietnam)

REGISTRATION

Registration is mandatory for all. Registration will be on first cum first serve basis. Proof of identity is required corresponding to each category. Participation certificate will be provided to all. Last date for registration is March 20, 2024.

International attendees

| | |
|------------|-------|
| Students | 75 € |
| Academic | 150 € |
| Industrial | 300 € |

Indian attendees (offline)

| | |
|------------|-------------|
| Students | 750 rupees |
| Academic | 1500 rupees |
| Industrial | 2500 rupees |

Indian attendees (online)

| | |
|------------|-------------|
| Students | 500 rupees |
| Academic | 1000 rupees |
| Industrial | 2000 rupees |

Amity Member: Free

To register click here: <https://amity.edu/nspg/FDPEMR2024>

INFORMATION

Contact: bmoulik@amity.edu

The summer school takes place in Amity University, Sector 125, Noida Uttar Pradesh, India.

More information: <https://emr-website.univ-lille.fr/>